

Operator's Manual

CRAFTSMAN®

7 1/4-in. Circular Saw

Model No.
172.10855
12 Amp

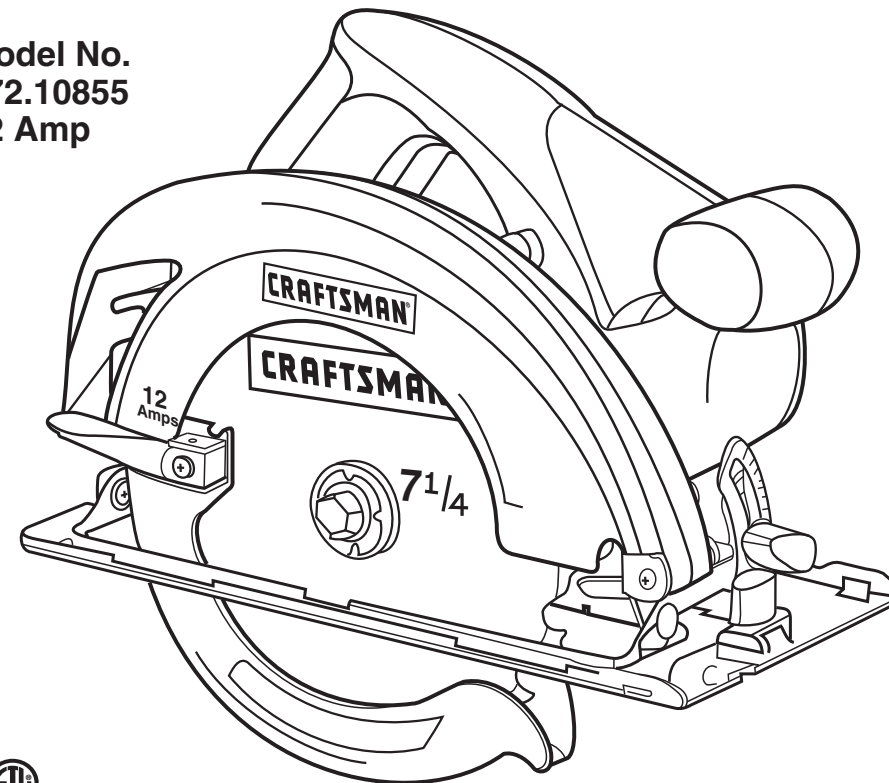

 **DOUBLE INSULATED**

CAUTION Read, understand and follow all Safety Rules and Operating Instructions in this Manual before using this product.

Sears, Roebuck and Co.,
Hoffman Estates, IL 60179 U.S.A.
Visit our Craftsman website: www.craftsman.com

- WARRANTY
- SAFETY
- UNPACKING
- ASSEMBLY
- DESCRIPTION
- OPERATION
- MAINTENANCE

REV 10855
2-12-08

TABLE OF CONTENTS

Warranty.....	Page 2
Safety Symbols.....	Page 3
Safety Instructions.....	Pages 4 - 10
Glossary of Terms.....	Pages 10 - 11
Unpacking	Pages 11 - 12
Assembly.....	Pages 12 - 13
Description	Pages 14 - 16
Operation	Pages 16 - 28
Maintenance.....	Pages 28 - 29
Troubleshooting.....	Page 29
Accessories.....	Page 29
Sears Repair Parts Phone Numbers.....	Back Cover

ONE YEAR FULL WARRANTY ON CRAFTSMAN® TOOL

If this Craftsman tool fails due to a defect in material or workmanship within one year from the date of purchase, **RETURN IT TO ANY SEARS STORE OR OTHER CRAFTSMAN OUTLET IN THE UNITED STATES FOR FREE REPLACEMENT.**

This warranty does not include expendable parts such as lamps, batteries, bits or blades.

If this Craftsman product is used for commercial or rental purposes, this warranty applies for only 90 days from the date of purchase.

This warranty gives you specific legal rights, and you may also have other rights which vary from state to state.

Sears, Roebuck and Co., Hoffman Estates, IL 60179

**SAVE THESE INSTRUCTIONS!
READ ALL INSTRUCTIONS!**

⚠ WARNING: Some dust created by using power tools contains chemicals known to the State of California to cause cancer and birth defects or other reproductive harm.

SAFETY SYMBOLS

The purpose of safety symbols is to attract your attention to possible dangers. The safety symbols, and the explanations with them, deserve your **careful attention and understanding**. The symbol warnings **DO NOT** by themselves eliminate any danger. The instructions and warnings they give are no substitutes for proper accident prevention measures.

⚠ WARNING: BE SURE to read and understand all safety instructions in this manual, including all safety alert symbols such as “DANGER”, “WARNING” and “CAUTION”, BEFORE using this drill/driver. Failure to follow all instructions listed below may result in electric shock, fire and/or serious personal injury.

SYMBOL MEANING

⚠ SAFETY ALERT SYMBOL: Indicates DANGER, WARNING, OR CAUTION. May be used in conjunction with other symbols or pictographs.

⚠ DANGER Failure to obey this safety warning **WILL** result in death or serious injury to yourself or to others. Always follow the safety precautions to reduce the risk of fire, electric shock and personal injury.

⚠ WARNING Failure to obey this safety warning **CAN** result in death or serious injury to yourself or to others. Always follow the safety precautions to reduce the risk of fire, electric shock and personal injury.

⚠ CAUTION Failure to obey this safety warning **MAY** result in personal injury to yourself or others or property damage. Always follow the safety precautions to reduce the risk of fire, electric shock and personal injury.

DAMAGE PREVENTION AND INFORMATION MESSAGES

These inform user of **important information and/or instructions** that could lead to equipment or other property damage if not followed. Each message is preceded by the word “NOTE:” as in the example below:

NOTE: Equipment and/or property damage may result if these instructions are not followed.



⚠ WARNING: The operation of any power tool can result in foreign objects being thrown into your eyes, which can result in severe eye damage. Before beginning power tool operation, **ALWAYS** wear safety goggles or safety glasses with side shield and a full-face shield when needed. We recommend a Wide Vision Safety Mask for use over eyeglasses or standard safety glasses with side shield, available at Sears Stores or other Craftsman Outlets.

SAFETY INSTRUCTIONS

⚠ WARNING: BE SURE to read and understand all instructions in this manual before using this circular saw. Failure to follow all instructions may result in hazardous radiation exposure, electric shock, fire and/or serious personal injury.

WORK AREA SAFETY

1. **Keep your work area clean and well lit.** Cluttered workbenches and dark areas invite accidents.
2. **DO NOT operate power tools in explosive atmospheres, such as in the presence of flammable liquids, gases, or dust.** Power tools create sparks which may ignite the dust or fumes.
3. **Keep bystanders, children and visitors away while operating a power tool.** Distractions can cause you to lose control.
4. **Make your workshop childproof** with padlocks and master switches. Lock tools away when not in use.
5. **MAKE SURE the work area has ample lighting** so you can see the work and that there are no obstructions that will interfere with safe operation **BEFORE** using your saw.

PERSONAL SAFETY

1. **KNOW your power tool.** Read the operator's manual carefully. Learn the saw's applications and limitations, as well as the specific potential hazards related to this tool.
2. **STAY ALERT,** watch what you are doing and use common sense when operating a power tool.
3. **DO NOT** use tool while tired or under the influence of drugs, alcohol or medication. A moment of inattention while operating power tools may result in serious personal injury.
4. **DRESS properly. DO NOT** wear loose clothing or jewelry. Pull back long hair. Keep your hair, clothing, and gloves away from moving parts. Air vents often cover moving parts and should also be avoided. Loose clothing, jewelry or long hair can be caught in moving parts.
5. **AVOID** accidental starting. Be sure switch is in "OFF" position before plugging in. **DO NOT** carry tools with your finger on the switch. Carrying tools with your finger on the switch or plugging in tools that have the switch in the "ON" position invites accidents.
6. **REMOVE** adjusting keys or wrenches before turning the tool "ON". A wrench that is left attached to a rotating part of the tool may result in personal injury.

SAFETY INSTRUCTIONS cont.

PERSONAL SAFETY cont.

7. **Do not overreach. Keep proper footing and balance at all times.** Proper footing and balance enables better control of the tool in unexpected situations.
8. **ALWAYS SECURE YOUR WORK.** Use clamps or a vise to hold work when practical. It is safer than using your hand and frees both hands to operate tool.
9. **USE SAFETY EQUIPMENT.** Always wear eye protection. Dust mask, non-skid safety shoes, hard hat, or hearing protection must be used for appropriate conditions.
10. **DO NOT USE ON A LADDER or unstable support.** Stable footing on a solid surface enables better control of the tool in unexpected situations.

TOOL USE AND CARE SAFETY

⚠ WARNING: BE SURE to read and understand all instructions before operating this saw. Failure to follow all instructions listed below may result in electric shock, fire and/or serious personal injury.

1. **ALWAYS use clamps or other practical ways to secure and support the workpiece to a stable platform.** Holding the work by hand or against your body is unstable and may lead to loss of control.
2. **DO NOT force the tool. Use the correct tool and blade for your application.** The correct tool and blade will do the job better and safer at the rate for which it is designed.
3. **DO NOT use the tool if switch does not turn it "On" or "Off".** Any tool that cannot be controlled with the switch is dangerous and must be repaired.
4. **DISCONNECT the plug from the power source before making any adjustments, changing accessories or storing the tool.** Such preventive safety measures reduce the risk of starting the tool accidentally.
5. **NEVER leave the tool running. ALWAYS turn it off. DO NOT** leave the tool until it comes to a complete stop.
6. **STORE idle tools out of the reach of children and other untrained persons.** Tools are dangerous in the hands of untrained users.
7. **MAINTAIN tools with care. Keep cutting tools sharp and clean.** Properly maintained tools with sharp cutting edges are less likely to bind and are easier to control.
8. **CHECK for misalignment or binding of moving parts, breakage of parts,** and any other condition that may affect the tool's operation. **If damaged,** have the tool serviced before using. Many accidents are caused by poorly maintained tools.
9. **USE ONLY accessories that are recommended for this tool.** Accessories that may be suitable for one tool may become hazardous when used on another tool.

SAFETY INSTRUCTIONS cont.

ELECTRICAL SAFETY

⚠️ WARNING: Do not permit fingers to touch the terminals of plug when installing or removing the plug from the outlet.

1. Double insulated tools are equipped with a polarized plug (one blade is wider than the other). This plug will fit in a polarized outlet only one way. If the plug does not fit fully in the outlet, reverse the plug. If it still does not fit, contact a **qualified electrician** to install a polarized outlet. Do not change the plug in any way.
2. Double insulation eliminates the need for the three-wire grounded power cord and grounded power supply system. Applicable only to Class II (double-insulated) tools. **This circular saw is a double insulated tool.**

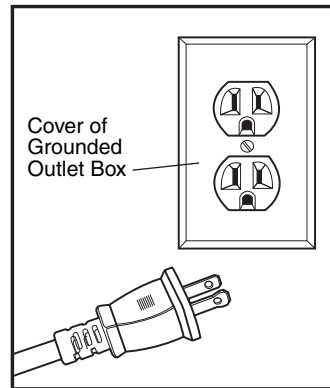

⚠️ WARNING: Double insulation **DOES NOT** take the place of normal safety precautions when operating this tool.

3. **BEFORE** plugging in the tool, **BE SURE** that the outlet voltage supplied is within the voltage marked on the tool's data plate. **DO NOT** use "AC only" rated tools with a DC power supply.
4. **AVOID body contact with grounded surfaces**, such as pipes, radiators, ranges and refrigerators. There is an increased risk of electric shock if your body is grounded.
5. **DO NOT expose power tools to rain or wet conditions or use power tools in wet or damp locations.** Water entering a power tool will increase the risk of electric shock.
6. **INSPECT tool cords for damage.** Have damaged tool cords repaired at a Sears Service Center. **BE SURE** to stay constantly aware of the cord location and keep it well away from the moving blade.
7. **DO NOT abuse the cord. NEVER use the cord to carry the tool by or pull the plug from the outlet.** Keep cord away from heat, oil, sharp edges or moving parts. Replace damaged cords immediately. Damaged cords increase the risk of electric shock.

SAFETY INSTRUCTIONS cont.

EXTENSION CORDS

Use a proper extension cord. ONLY use cords listed by Underwriters Laboratories (UL). Other extension cords can cause a drop in line voltage, resulting in a loss of power and overheating of tool. For this tool an AWG (American Wire Gauge) size of at least 14-gauge is recommended for an extension cord of 25-ft. or less in length. Use 12-gauge for an extension cord of 50-ft. **Extension cords 100-ft. or longer are not recommended.** Remember, a smaller wire gauge size has greater capacity than a larger number (14-gauge wire has more capacity than 16-gauge wire; 12-gauge wire has more capacity than 14-gauge). When in doubt use the smaller number. When operating a power tool outdoors, use an outdoor extension cord marked "W-A" or "W". These cords are rated for outdoor use and reduce the risk of electric shock.

⚠️ CAUTION: Keep the extension cord clear of the working area. Position the cord so that it will not get caught on lumber, tools or other obstructions while you are working with a power tool.

⚠️ WARNING: Check extension cords before each use. If damaged replace immediately. Never use tool with a damaged cord since touching the damaged area could cause electrical shock, resulting in serious injury.

SAFETY SYMBOLS FOR YOUR TOOL

The label on your tool may include the following symbols.

- V.....Volts
- A.....Amps
- Hz.....Hertz
- W.....Watts
- ~.....Alternating current
- — —.....Direct current
- n₀.....No-load speed
-Class II construction, Double Insulated
- RPM.....Revolutions per minute
- SPM.....Strokes per minute
- OPM.....Orbits per minute
- ⚠️.....Indicates danger, warning or caution.
It means attention! Your safety is involved.

SERVICE SAFETY

1. If any part of this saw is missing or should break, bend, or fail in any way; or should any electrical component fail to perform properly: **SHUT OFF** the power switch and remove the saw plug from the power source and have the missing, damaged or failed parts replaced **BEFORE** resuming operation.
2. **Tool service must be performed only at a Sears Parts and Repair Center.** Service or maintenance performed by unqualified personnel could result in a risk of injury.
3. **When servicing a tool, use only identical replacement parts. Follow instructions in the maintenance section of this manual.** Use of unauthorized parts or failure to follow maintenance instructions may create a risk of electric shock or injury.

SAFETY INSTRUCTIONS cont.

SAFETY RULES FOR CIRCULAR SAWS

⚠ DANGER: Keep hands away from cutting area and blade. Keep your second hand on the auxiliary handle or motor housing. If both hands are holding the saw, the blade cannot cut them.

⚠ CAUTION: Blades coast after saw is switched off.

1. **KEEP** your body positioned to either side of the saw blade and not in direct line with the saw blade. Kickback could cause the saw to jump backwards. (See "Kickback...What Causes It and Ways to Prevent It" on pages 18 and 19).
2. **DO NOT** reach underneath the work. The guard cannot protect you from the blade beneath the workpiece.

⚠ DANGER: When sawing through a workpiece, the lower blade guard **DOES NOT** cover the blade on the underside of the workpiece (Pg. 17 Fig. 4). **ALWAYS** keep your hands and fingers away from the cutting area.

3. **CHECK** lower guard for proper closing **BEFORE** each use. **DO NOT** operate the saw if the lower guard does not move freely and close instantly. Never clamp or tie the lower guard in the open position. If the saw is accidentally dropped, the lower guard may be bent. Raise the lower guard with the retracting lever. The guard is operating properly when it moves freely, does not touch the blade or any other part in all angles and depths of cut, and readily returns to the closed position.
4. **CHECK** the operation and condition of the lower guard spring. If the guard and the spring are not operating properly, they **MUST BE serviced before use**. The lower guard may operate sluggishly, due to damaged parts, gummy deposits, or a buildup of debris. **DO NOT** operate your saw until the damage has been repaired or replaced.
5. The lower guard should be retracted manually **ONLY** for making special cuts, such as pocket or compound cuts. **ALWAYS** raise the lower guard by retracting its lever. As soon as the blade enters the material, the lower guard **MUST** be released. For all other sawing, the lower guard should operate automatically.
6. **ALWAYS** make sure that the lower guard is covering the blade **BEFORE** placing the saw down on a work bench or floor. An unprotected moving blade will cause the saw to walk backwards, cutting whatever is in its path. Make note of the time it takes for the blade to stop spinning after the switch is released.
7. **NEVER** hold the piece being cut in your hands or across your legs. It is important to support the workpiece properly in order to minimize body exposure, blade binding, or loss of control.
8. **HOLD TOOL** by insulated gripping surfaces (handles) when performing an operation where the cutting tool may contact hidden wiring or its own cord. Contact with a "live" wire will make the exposed metal parts of the tool "live" and shock the operator.
9. **ALWAYS** clamp the workpiece securely so it will not move when making the cut.
10. When ripping, **ALWAYS** USE a rip fence or straight edge guide. This improves the accuracy of the cut and reduces the chance of the blade binding.
11. **ALWAYS** USE blades that have the correct size and shape (diamond vs. round) arbor holes. Blades that do not match the mounting hardware of the saw will run erratically and cause loss of control.

SAFETY INSTRUCTIONS cont.

SAFETY RULES FOR CIRCULAR SAWS cont.

11. **ALWAYS** USE blades that have the correct size and shape (diamond vs. round) arbor holes. Blades that do not match the mounting hardware of the saw will run erratically and cause loss of control.
12. **NEVER** use damaged or incorrect blade washers or bolts. The blade washers and bolts were specially designed for your saw, for optimum performance and safety of operation.
13. **NEVER** cut more than one piece at a time. **DO NOT STACK** more than one workpiece on the worktable at a time.
14. **AVOID** awkward operations and hand positions where a sudden slip could cause your hand to move into the blade.
15. **NEVER** reach into the cutting path of the blade.

⚠ WARNING: WARNING: Some dust created by using power tools contains chemicals known to the State of California to cause cancer and birth defects or other reproductive harm. Some examples of these chemicals are:

- Lead from lead-based paints.
- Crystalline silica from bricks and cement and other masonry products.
- Arsenic and chromium, from chemically treated lumber.

Your risk from these exposures varies, depending upon how often you do this type of work. To reduce your exposure to these chemicals:

- Work in a well-ventilated area.
- Work with approved safety equipment, such as those dust masks that are specially designed to filter out microscopic particles.

Avoid prolonged contact with dust from power sanding, sawing, grinding, drilling and other construction activities. Wear protective clothing and wash exposed areas with soap and water. Allowing dust to get into your mouth, eyes, or lay on the skin may promote absorption of harmful chemicals.

⚠ WARNING: Use of this tool can generate and/or disburse dust, which may cause serious and permanent respiratory or other injury. Always use NIOSH/OSHA approved respiratory protection appropriate for the dust exposure. Direct particles away from face and body.

ADDITIONAL RULES FOR SAFE OPERATION

⚠ WARNING: BE SURE to read and understand all instructions. Failure to follow all instructions listed below may result in electric shock, fire and/or serious personal injury.

1. **Know your power tool.** Read operator's manual carefully. Learn the applications and limitations, as well as the specific potential hazards related to this tool. Following this rule will reduce the risk of electric shock, fire or serious injury.
2. **ALWAYS** wear safety glasses or eye shields when using this saw. Everyday eyeglasses have only impact-resistant lenses; they are **NOT** safety glasses.
3. **PROTECT** your lungs. Wear a face mask or dust mask if the operation is dusty.

SAFETY INSTRUCTIONS cont.

ADDITIONAL RULES FOR SAFE OPERATION cont.

- PROTECT your hearing.** Wear appropriate personal hearing protection during use. Under some conditions and duration of use, noise from this product may contribute to hearing loss.
- ALL VISTORS AND BYSTANDERS MUST** wear the same safety equipment that the operator of the saw wears.
- INSPECT the tool cords periodically and if damaged have them repaired at your nearest Sears Service Center or other Authorized Service Facility. BE AWARE of the cord location.**
- ALWAYS check the tool for damaged parts. Before** further use of the tool, a guard or other part that is damaged should be carefully checked to determine if it will operate properly and perform its intended function. Check for misalignment or binding of moving parts, breakage of parts, and any other condition that may affect the tool's operation. A guard or other part that is damaged should be properly repaired or replaced at a Sears Service center.
- INSPECT and remove all nails from lumber before sawing.**
- SAVE THESE INSTRUCTIONS. Refer to them frequently and use them to instruct others who may use this tool. If someone borrows this tool, make sure they have these instructions also.**

GLOSSARY OF TERMS FOR WOODWORKING

Spindle

The shaft on which a blade or cutting tool is mounted. Also called the Arbor.

Revolutions Per Minute (RPM)

The number of turns completed by a spinning object in one minute.

Saw Blade Path

The area over, under, behind or in front of the blade, as it applies to the workpiece. That area which will be or has been cut by the blade.

Set

The distance that the saw blade tooth is bent (or set) outward from the face of the blade.

Miter Cut

A cutting operation made with the blade at any angle other than 90° to the fence.

Compound Miter Cut

A compound miter cut is a cut made using a miter angle and a bevel angle at the same time.

Cross cut

A cutting or shaping operation made against the grain of the workpiece.

Bevel Cut

A cutting operation made with the blade at any angle other than 90° to the miter table.

Dado Cut

A non-through cut which produces a square-sided notch or trough in the workpiece (requires special blade).

Chamfer Cut

A cut removing a wedge from a block of wood so the end (or part of the end) is angled at other than 90°.

GLOSSARY OF TERMS FOR WOODWORKING

Ripping or Rip Cut

A cutting operation along the length of the workpiece.

Freehand Cut

Performing a cut without using a fence, miter gauge, fixture, work clamp, or other proper device to keep the workpiece from twisting or moving during the cut.

Through Sawing

Any cutting operation where the blade extends completely through the thickness of the workpiece.

Non-Through Cuts

Any cutting operation where the blade does not extend completely through the thickness of the workpiece, like a dado cut.

Leading End

The end of the workpiece pushed into tool first.

Kerf

The material removed by the blade in a through cut or the slot produced by the blade in a non-through or partial cut.

Kickback

A hazard that can occur when the blade binds or stalls, throwing the workpiece back toward operator.

Workpiece or Material

The item on which the cutting operation is being done. The surfaces of a workpiece are commonly referred to as faces, ends and edges.

Gum

A sticky, sap-based residue from wood products.

Resin

A sticky, sap-based substance that has hardened.

UNPACKING

⚠ WARNING: Your saw should NEVER be connected to the power source when you are assembling parts, making adjustments, installing or removing blades, cleaning or when it is not in use. Disconnecting the saw will prevent accidental starting, which could cause serious personal injury.

- Included with your circular saw is the **cutting blade**, which is unassembled and packed separately. Also a blade wrench is stored in the saw's base, for use in installing or changing the blade.
- Inspect the saw carefully to make sure that no breakage or damage has occurred during shipping. If any of the items mentioned are missing (refer to PARTS LIST illustration see Fig.1 page 12), return the saw to your nearest Sears store or Craftsman outlet to have the saw replaced.

⚠ WARNING: If any parts are broken or missing, DO NOT attempt to plug in the power cord or operate saw until the broken or missing parts are replaced. Failure to do so could result in possible serious injury.

UNPACKING cont.

PARTS LIST (Fig. 1)

3. Blade Wrench
(for changing the blade)



4. Operator's Manual

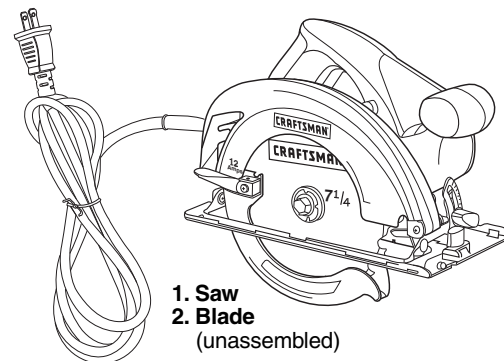

ASSEMBLY

INSTALLING THE BLADE (Figs. 2 and 2a)

Carefully remove the blade from its packing, inspect it to be sure that it is not cracked or damaged.

1. Saw **should not** be plugged into power source.

WARNING: To prevent personal injury, ALWAYS disconnect the plug from power source BEFORE assembling parts, making adjustments or installing blades.

- Place saw on its side on a flat surface.
- To loosen the depth-of-cut adjustment lever, raise the saw up all the way and tighten lever. This gives you easier access to blade mounting area (see Fig. 2a).
- Place saw upright, on its base and on a flat surface (see Fig. 2a).
- To loosen the spindle clamping screw "A", depress the spindle lock button (see Fig. 2). Place the blade wrench on the spindle clamping screw "A". Move the wrench back and forth until you feel the spindle lock button depress further and it locks the blade in position so the spindle clamping screw can be removed. Keeping the spindle lock button firmly depressed, turn the spindle screw counterclockwise to remove.

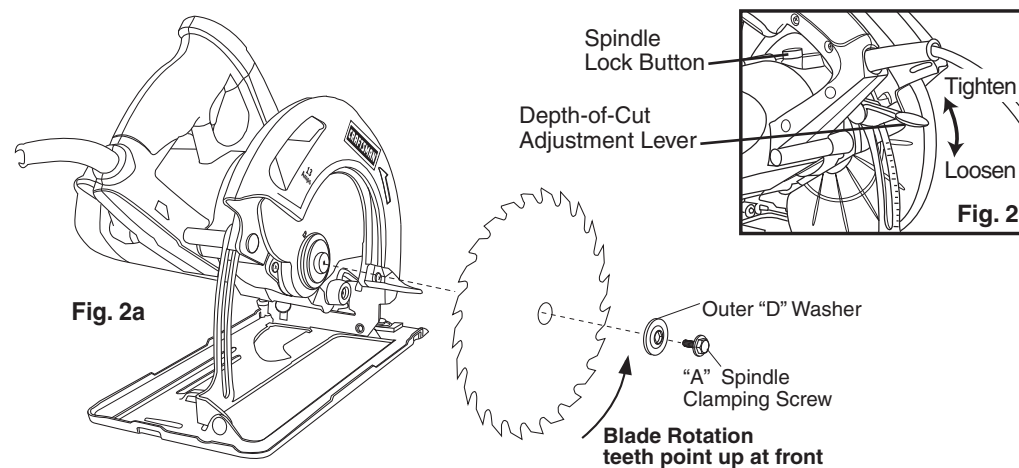

12

ASSEMBLY cont.

INSTALLING THE BLADE cont. (Figs. 2 and 2a)

WARNING: BE SURE to wear protective work gloves while handling a saw blade. The blade can injure unprotected hands.

WARNING: A 7 1/4-inch blade is the maximum blade capacity of your saw. A larger than 7 1/4-inch blade will come in contact with the blade guards. Also, NEVER use a blade that is so thick that it prevents the outer blade washer from engaging with the flat side of the spindle. Blades that are too large or too thick can result in an accident causing serious injury.

- Completely remove the spindle clamping screw "A" and the outer "D" washer (see Fig. 2a).
- The remaining washer is the inner bushing washer that fits around the spindle shaft and it does not need to be removed.
- Put a drop of oil onto the inner bushing washer and outer "D" washer where they will touch the blade.
- Raise lower blade guard using the blade guard lever and hold it in the raised position for the next step.
- Place the saw blade inside the lower blade guard, onto the spindle shaft and against the inner bushing.

NOTE: The teeth of the blade should point upward at the front of the saw as shown in (Fig. 2a).

- Replace the "D" washer.
- Firmly hold down spindle lock button as you replace the spindle screw and hand tighten it in a clockwise direction. Then use blade wrench to tighten the spindle clamping screw thoroughly.

NOTE: NEVER use a blade that is too thick to allow the "D" washer to engage with the flat side of the spindle.

REMOVING THE BLADE (Figs. 2 and 2a)

- Unplug the saw.
- Follow steps 2. through 6. of "INSTALLING THE BLADE" and remove the blade (see Fig. 2a).

13

DESCRIPTION

KNOW YOUR CIRCULAR SAW (Fig. 3)

NOTE: Before attempting to use your saw, familiarize yourself with all of the operating features and safety requirements.

Your circular saw has a precision-built electric motor and it should only be connected to a 120-volt, 60-Hz AC ONLY power supply (normal household current). **DO NOT** operate on direct current (DC). This large voltage drop will cause a loss of power and the motor will overheat. If the saw does not operate when plugged into correct 120-volt, 60-Hz AC ONLY outlet, check the power supply. The saw has an 8-ft., 2-wire power cord (no adapter needed).

This Circular Saws have the following features:

1. **9-10855 12 Amp, 4800 RPM (no-load speed) motor** provides power and torque for fast, sure cuts in wood, plywood, hardboard and wood-base materials.
2. **Quick depth-of-cut adjustments** with a maximum depth of cut:
9-10855 - 2⁷/₁₆-in. at 90°; 1¹³/₁₆-in. at 45°
3. **Easy to read Bevel Cut Scale** adjusts bevel capacity;
9-10855 ; 0° to 45°
4. **Die-cast aluminum blade guards** are epoxy coated for durability and extra strength
5. **Extended length Trigger Switch with Power Lock-off Button** for maximum control and comfort. Power lock-off button must be pressed in for trigger switch to turn saw "on".
6. **Large stamped Steel Base** provides stability, glides smoothly
7. **Ergonomically designed Rear Handle and Front Assist Handle** provide positive gripping, control, balance and comfort.
8. **Includes Craftsman® 24 tooth carbide-tipped steel combination blade.**
9. **Top mounted Blade Spindle Lock** for easy blade changes.
10. **Sawdust ejection chute** helps direct dust and chips away from operator.
11. **Permanently lubricated 100% ball bearings** for smooth operation and long life.
12. **Durable machined gearing** for efficient power transmission.

DESCRIPTION cont.

This Circular Saws have the following features: cont.

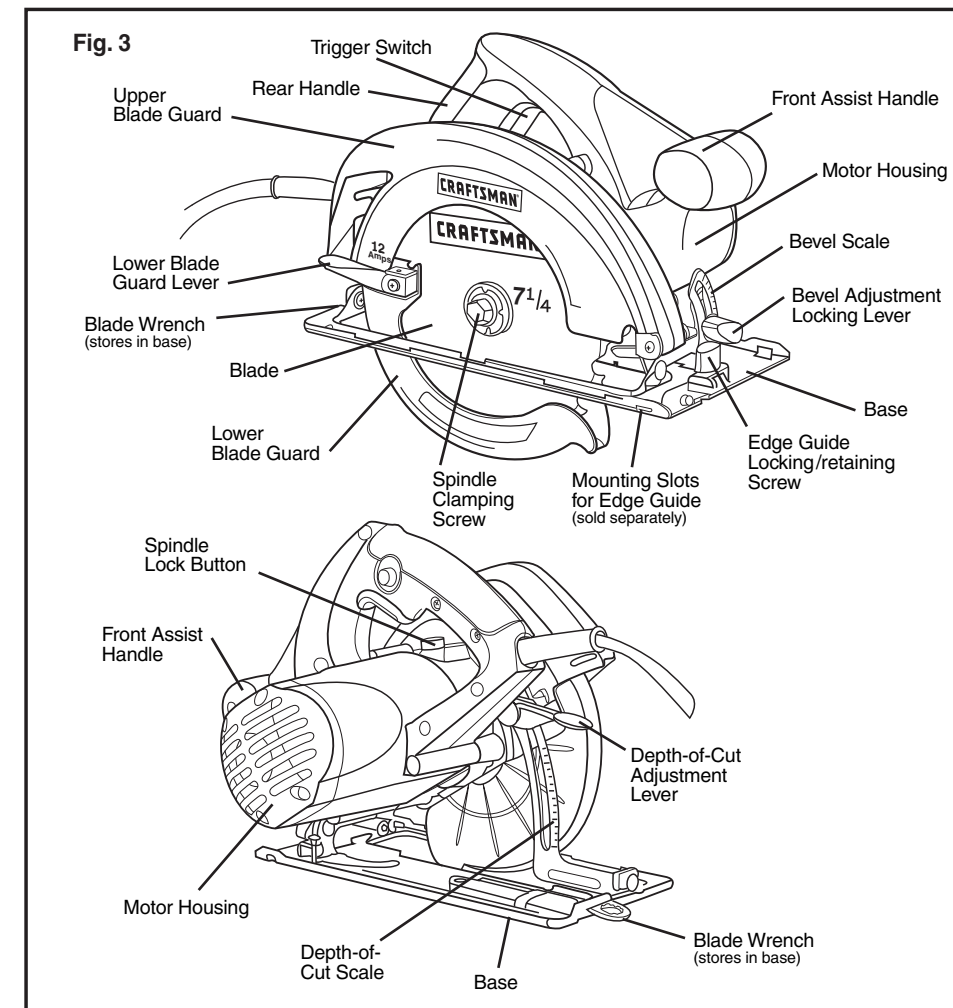

PRODUCT SPECIFICATIONS 9-10855

Input	12 Amps
Rating	120V, 60Hz AC
No Load Speed	4800 RPMs
Cutting Depth at 90°	2 ⁷ / ₁₆ -in. (61.97mm)
Cutting Depth at 45°	1 ¹³ / ₁₆ -in. (46.03 mm)
Maximum Bevel Angle	45°
Blade Diameter	7 ¹ / ₄ -in. (184 mm)

OPERATION

SAW BLADES

All saw blades need to be kept clean, sharp and properly set in order to cut efficiently. Using a dull blade places a heavy load on the saw and increases the danger of kickback. Keep extra blades on hand, so sharp blades are always available. Gum and wood pitch hardened on the blade slows the saw down. Use gum and pitch remover, hot water or kerosene to remove them. **DO NOT** use gasoline.

BLADE GUARD SYSTEM (Fig. 4)

The lower blade guard, attached to your circular saw, is there for your protection and safety. It should **NEVER** be altered for any reason. If it becomes damaged or begins to return slowly or sluggishly, **DO NOT** operate your saw until the damage has been repaired or replaced. **ALWAYS** leave the guard in its correct operating position when using the saw.

⚠ CAUTION: NEVER use the saw when the guard is not operating properly. The guard should be checked for correct operation before each use. If you drop your saw, check the lower blade guard and bumper for damage at all depth settings before using.
NOTE: The guard is operating properly when it moves freely and then readily returns to the closed position. If for any reason your lower blade guard and bumper does not close freely, take the saw to your nearest Sears Repair Center for service before using it.

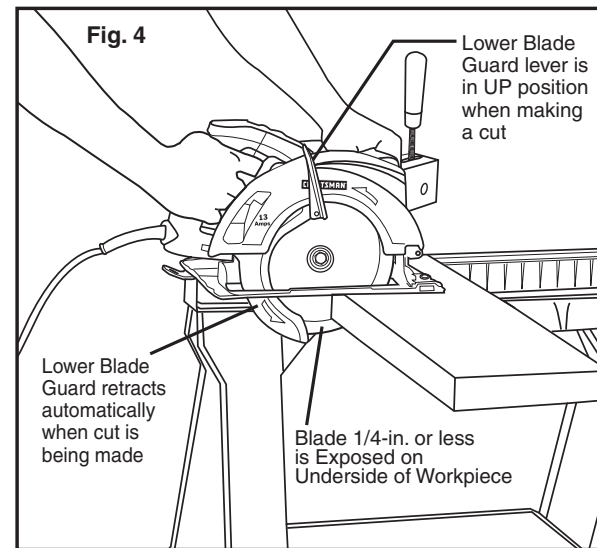

OPERATION cont.

KICKBACK...WHAT CAUSES IT AND WAYS TO HELP PREVENT IT (Fig. 5)

The Causes of Kickback

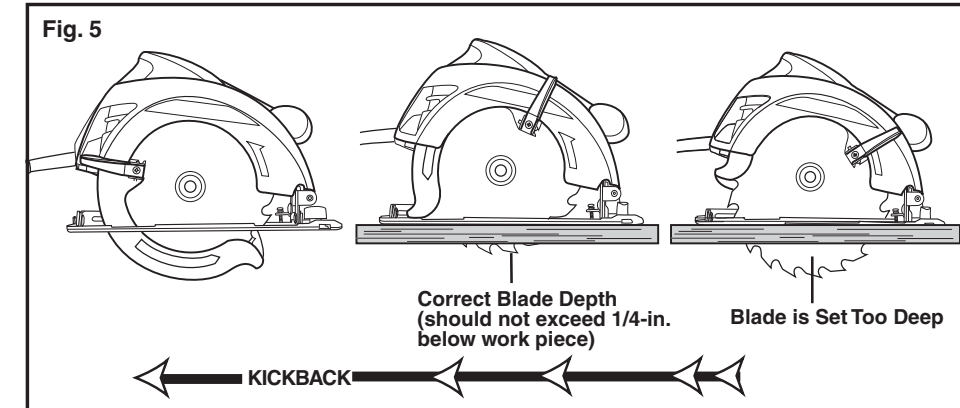

1. Kickback is a sudden reaction to a pinched, bound or misaligned saw blade, which causes an uncontrolled saw to lift up and out of the workpiece and toward the operator.
2. When the blade is pinched or bound tightly by the kerf closing down, the blade stalls and the motor reaction drives the unit rapidly back towards the operator.
3. If the blade becomes twisted or misaligned in the cut, the teeth at the back edge of the blade can dig into the top surface of the wood. This causes the blade to climb out of the kerf and jump back towards the operator.
4. Sawing into knots or nails in the workpiece can cause Kickback.
5. Sawing into wet or warped lumber can cause Kickback. (see Fig. 6a)
6. Forcing a cut, or not supporting the workpiece correctly can cause Kickback. (see Fig. 6a)
7. Kickback is a result of tool misuse and/or incorrect operating procedures or conditions. It can be avoided by taking the proper precautions, on page 19.

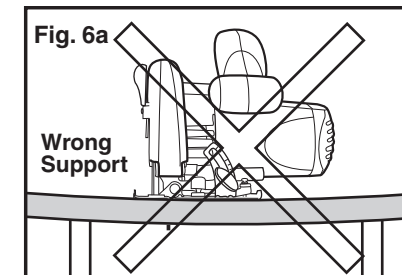
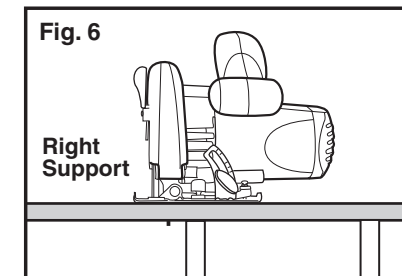

OPERATION cont.

Ways to Help Prevent Kickback

⚠ DANGER: ALWAYS release trigger switch immediately if the blade binds or the saw stalls. Kickback could cause you to lose control of the saw. Loss of control can lead to serious injury.

1. **ALWAYS** maintain a firm grip with both (see Fig. 7) hands on the saw and position your body and arms to allow you to resist Kickback forces. Kickback forces can be controlled by the operator, if the proper precautions are taken.
2. If the blade is binding, or when you are interrupting a cut for any reason, **ALWAYS** release the trigger and hold the saw motionless in the material until the blade comes to a complete stop. **NEVER** attempt to remove the saw from the work or pull the saw backward while the blade is in motion, or Kickback may occur. **CHECK** and take corrective action to eliminate the cause of blade binding.
3. Inspect the workpiece for knots or nails before cutting. Never saw into a knot or nail.
4. **DO NOT** cut warped or wet lumber. (see Fig. 6a)
5. **ALWAYS** support large panels to minimize the risk of blade pinching and Kickback. Large panels tend to sag under their own weight (see Fig. 6a). Supports **MUST** be placed under the panel, one near the line of cut and one near the edge of the panel (see Fig. 6).
6. When restarting the saw in the workpiece, **CENTER** the blade in the kerf and check to be sure that the saw teeth are not engaged into the material. If the saw blade is binding, it may walk up or Kickback from the workpiece when the saw is restarted.
7. **DO NOT** use a dull or damaged blade. Unsharpened, improperly set, or gummed-up blades produce narrow kerf which causes excessive friction, blade binding and Kickback.
8. **KEEP** the blade at the correct depth setting. The depth setting should not exceed 1/4-inch below the material being cut (see Fig. 5). **BE SURE** that the blade depth and adjusting locking levers are tight and secure **BEFORE** making a cut. If blade adjustment shifts while cutting it may cause binding and Kickback.
9. **USE EXTRA CAUTION** when making a "Pocket Cut" into existing walls or other blind areas. The protruding blade may cut objects that can cause Kickback.

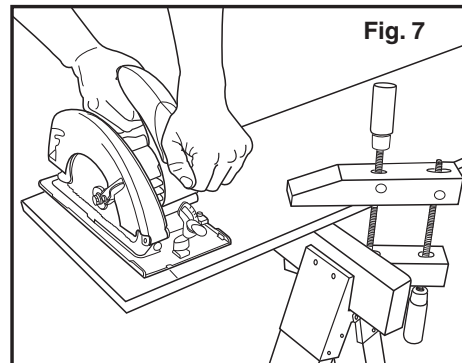

OPERATION cont.

MAKING DEPTH-OF-CUT ADJUSTMENTS (Fig. 8)

ALWAYS use the correct blade depth setting. The correct blade depth setting for all cuts should not be more than 1/4-inch below the material being cut (see Fig 5). Allowing more depth will increase the chance of kickback and cause the cut to be rough. Your saw is equipped with a depth-of-cut scale that provides increased depth-of-cut accuracy. The depth-of-cut scale is located on the inside back of the upper blade guard.

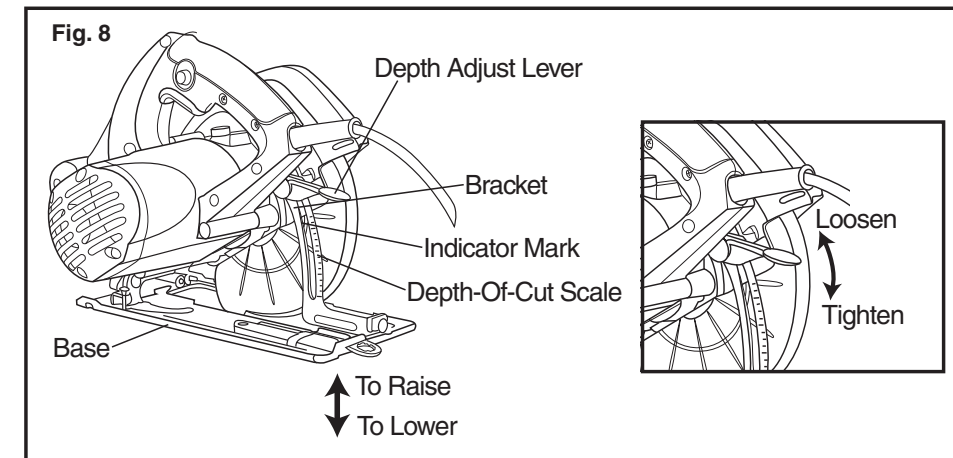

TO SET THE BLADE DEPTH (Fig. 8a)

1. Unplug the saw.

⚠ WARNING: ALWAYS unplug saw before making any adjustments. Failure to unplug the saw could result in accidental starting which can cause serious personal injury.

2. Raise the depth-of-cut adjustment lever to loosen the base (see Fig. 8).
3. Determine the desired depth of cut.
4. Locate the depth-of-cut scale on the back of the upper blade guard (see Fig. 8a).
5. Hold the base of the saw flat against the edge of the workpiece and then raise or lower the saw until the indicator mark on the bracket aligns with the notch on the blade guard at the desired depth-of-cut mark.
6. Tighten depth-of-cut adjustment lever.

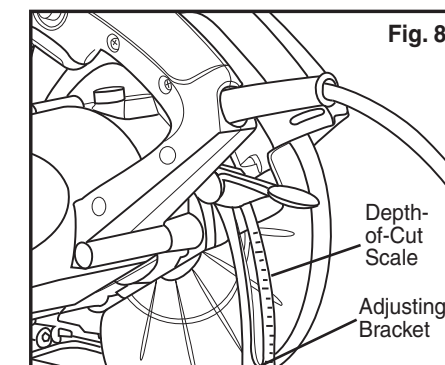

OPERATION cont.

STARTING A CUT (Fig. 10)

⚠ WARNING: ALWAYS clamp and support workpiece securely. ALWAYS maintain proper control of saw. Failure to clamp and support workpiece and loss of control of saw could result in serious injury.

1. ALWAYS use your saw with your hands positioned correctly, with one hand operating the trigger switch and the other on the front assist handle (see Fig. 10).

⚠ WARNING: ALWAYS maintain proper control of the saw to make sawing safer and easier. Loss of control of the saw could cause an accident resulting in possible serious injury.

2. NEVER use the saw with your hands positioned as shown in Fig. 11

To Help Maintain Control:

3. ALWAYS support the workpiece near the cut.
4. ALWAYS support the workpiece so the cut will be on your right.
5. ALWAYS clamp the workpiece so it will not move during the cut. Place the workpiece with the good side down.

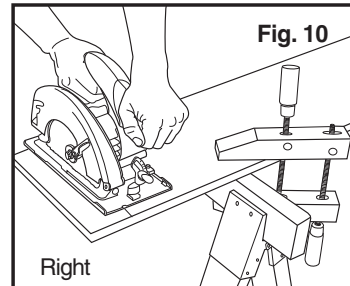

NOTE: The good side of the workpiece is the side where appearance is important.

6. Before starting a cut, draw a guideline along the desired line of cut, then place the front edge of the saw base on that part of the workpiece that is solidly supported (see Fig.10).
7. NEVER place the saw on the part of the workpiece that will fall off when the cut is made (see Fig. 11).
8. ALWAYS keep the cord away from the cutting area. ALWAYS place the cord so it does not hang up on the workpiece when making a cut.
9. Hold the saw firmly with both hands (see Fig 10).

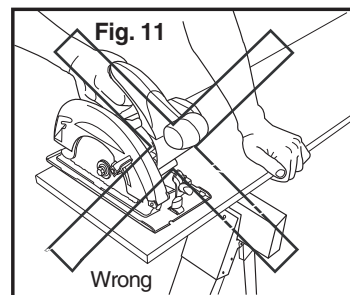

⚠ WARNING: If the cord hangs up on the workpiece during a cut, release the trigger switch immediately. To avoid injury, unplug the saw and move the cord to prevent it from hanging up again.

⚠ DANGER: Using the saw with a damaged cord could result in serious injury or death. If the cord has been damaged, have it replaced before using the saw again.

OPERATION cont.

TO HELP MAINTAIN CONTROL cont.:

10. Squeeze the trigger switch to start the saw. ALWAYS let the blade reach full speed before you begin the cut into the workpiece.
11. When making a cut, ALWAYS use steady, even pressure. Forcing the saw causes rough cuts and could shorten the life of the saw or cause Kickback.
12. After completing your cut, release the trigger switch and allow the blade to come to a complete stop. DO NOT remove the saw from the workpiece while the blade is moving.

⚠ DANGER: When sawing through a workpiece, the lower blade guard DOES NOT cover the blade on the underside of the workpiece (see Fig. 4, page 17). ALWAYS keep your hands and fingers away from the cutting area. Any part of your body coming in contact with the moving blade will result in serious injury.

MAKING CROSS CUTS AND RIP CUTS (Fig. 12 and 12a)

⚠ WARNING: ALWAYS clamp and support workpiece securely. ALWAYS maintain proper control of saw. Failure to clamp and support workpiece and loss of control of saw could result in serious injury.

1. ALWAYS use your saw with your hands positioned correctly (see Fig. 12).

⚠ WARNING: ALWAYS maintain proper control of the saw to make sawing safer and easier. Loss of control of the saw could cause an accident resulting in possible serious injury.

2. When making cross or rip cuts with the 10855, align your line of cut with the right side of the notch by the 0° indicator (see Fig. 12).

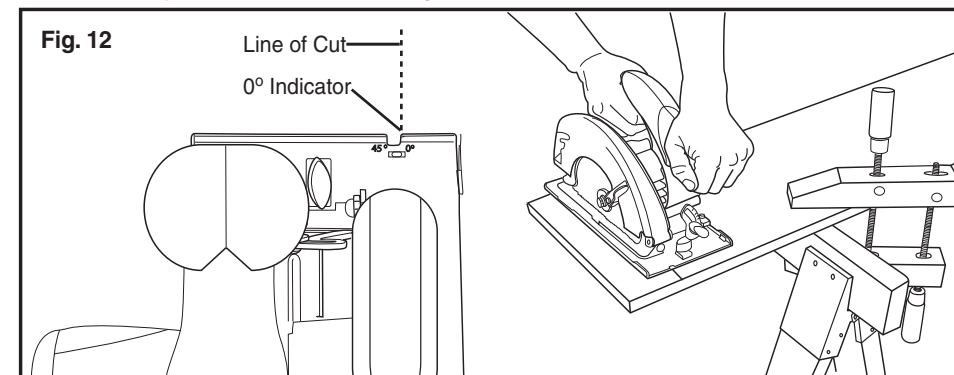

NOTE: Since the thickness of blades varies, MAKE A TRIAL CUT in scrap material along the guideline to determine how much, if any, you should offset the blade from the guideline to allow for the kerf of the blade to get an accurate cut.

OPERATION cont.

MAKING RIP CUTS

ALWAYS use a guide when making long or wide rip cuts with your saw. You can use either a straight edge or use the edge guide that was included with your saw.

⚠ WARNING: ALWAYS clamp and support workpiece securely. ALWAYS maintain proper control of saw. Failure to clamp and support workpiece combined with loss of control of saw could result in serious injury.

1. You can make an efficient rip guide by clamping a straight edge to your workpiece.
2. Carefully guide the saw along the straight edge for a straight rip cut (see Fig. 13).
3. **ALWAYS LET THE BLADE REACH FULL SPEED, then carefully** guide the saw into the workpiece. **DO NOT bind the blade in the cut.** Push the saw forward at a speed where the blade is not laboring.

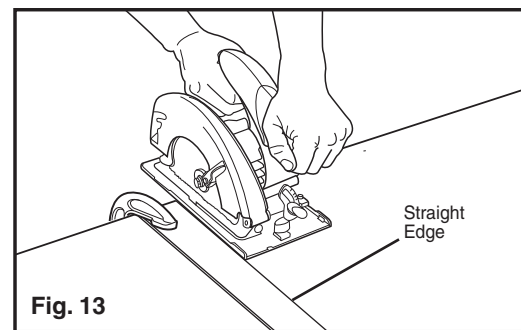

INSTALLING AND USING THE EDGE GUIDE (sold separately) (Fig. 14)

Edge guide allows you to make accurate parallel cuts when trimming a workpiece. It attaches to the saw's base.

1. Unplug the saw.

⚠ WARNING: ALWAYS unplug saw before making any adjustments. Failure to unplug the saw could result in accidental starting which can cause serious personal injury.

2. Position the edge guide so the arm with the inch increments is facing "up". Slide the arm of the edge guide into the mounting slots at the front of the saw's base (see Fig. 14).
3. Adjust the edge guide to the desired length of cut.
4. Tighten the edge guide retaining screw.
5. Clamp and support the workpiece securely before making your cut.
6. Place the edge guide firmly against the edge of the workpiece (See Fig. 14). Doing this will give you a true cut without pinching the blade.
7. **BE SURE** that the guiding edge of the workpiece is straight so you can get a straight cut.
8. **ALWAYS LET THE BLADE REACH FULL SPEED,** then carefully guide the saw into the workpiece. **DO NOT** bind the blade in the cut. Push the saw forward at a speed where the blade is not laboring.

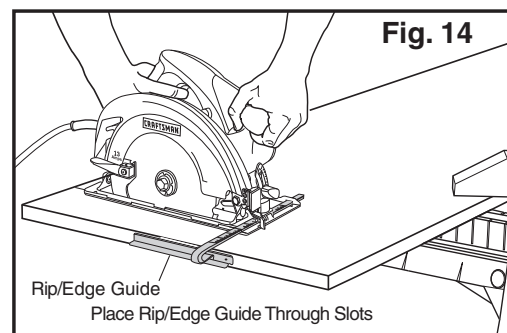

22

OPERATION cont.

HOW TO SET YOUR BEVEL ANGLE (Fig. 15)

1. Unplug the saw.

⚠ WARNING: ALWAYS unplug saw before making any adjustments. Failure to unplug the saw could result in accidental starting which can cause serious personal injury.

2. Loosen bevel adjustment lever (see Fig. 15).
3. Raise the motor housing end of the saw until you reach the desired angle setting on the bevel scale.
4. Tighten the adjustment lever securely.

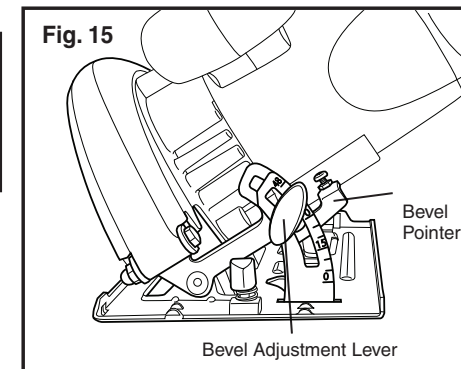

MAKING BEVEL CUTS (Figs. 16)

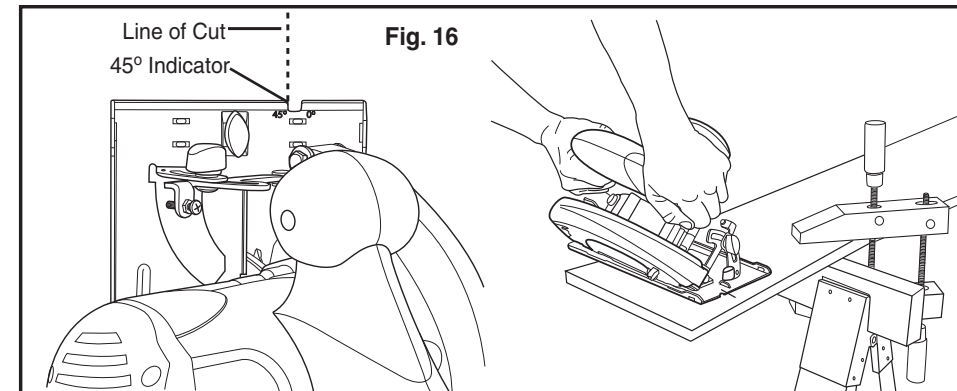

⚠ WARNING: ALWAYS clamp and support workpiece securely. ALWAYS maintain proper control of saw. Failure to clamp and support workpiece and loss of control of saw could result in serious injury.

1. Your saw can be adjusted to cut at any angle between 0° and 45°.
2. When making 45° bevel cuts, line the left side of the notch in the saw's base with the penciled line of cut on your workpiece (see Fig. 13).
3. When making a bevel cut **HOLD** the saw **FIRMLY** with both hands (see Fig. 16).
4. Rest the front edge of the base on the workpiece, then squeeze the trigger switch to start the saw. **ALWAYS** let the blade reach full speed, then guide the saw into the workpiece.
5. After completing your cut, release the trigger switch and allow the blade to come to a complete stop in the cut. **DO NOT** remove the saw from the workpiece while the blade is moving. It will damage your bevel cut and cause Kickback.

23

OPERATION cont.

MAKING BEVEL CUTS (Figs. 16) cont.

⚠ WARNING: If the blade comes in contact with the workpiece before it reaches full speed, it could cause the saw to kickback towards you, possibly resulting in serious injury.

NOTE: Since the thickness of blades varies, **MAKE A TRIAL CUT** in scrap material along the guideline to determine how much, if any, you should offset the blade from the guideline to allow for the kerf of the blade to get an accurate cut.

MAKING POCKET CUTS (Fig. 17)

⚠ WARNING: **ALWAYS** adjust bevel setting to zero before making a pocket cut. Attempting a pocket cut at any other setting can result in a loss of control of the saw, which can result in serious injury.

1. Adjust the bevel setting to zero, set the blade to the correct blade depth setting, then use the lower blade guard lever to swing the guard up.

⚠ WARNING: **ALWAYS** raise the lower blade guard with the lever to avoid serious injury.

2. While holding the lower blade guard up by the lever, firmly rest the front of the saw base flat against the workpiece with the rear handle raised so the blade **does not** touch the workpiece (see Fig 17).

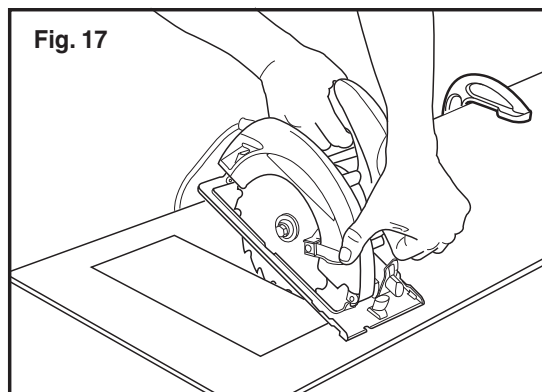

3. Squeeze the trigger switch to start the saw. **ALWAYS** let the blade reach full speed, then slowly lower the blade onto the workpiece until the base is flat against the workpiece. **AS the blade enters the material, you MUST release the lower blade guard lever.**
4. After you complete the cut, release the trigger switch and allow the blade to come to a complete stop. After the blade has stopped, remove it from the workpiece. If the corners of your pocket cut are not completely cut through, use a hand finishing saw to finish the corners.

⚠ WARNING: **NEVER** tie the lower blade guard in the raised position. Leaving the blade exposed could result in serious injury.

MAINTENANCE

⚠ WARNING: To ensure safety and reliability, all repairs - with the exception of the externally accessible brushes - should be performed by a qualified service technician at a Sears Service Center.

⚠ WARNING: For your safety, **ALWAYS** turn off switch and unplug circular saw from the power source before performing any maintenance or cleaning.

It has been found that electric tools are subject to accelerated wear and possible premature failure when they are used to work on fiber glass boats and sports cars, wallboard, spackling compounds or plaster. The chips and grindings from these materials are highly abrasive to electrical tool parts, such as bearings, brushes, commutators, etc. Consequently, it is not recommended that this tool be used for extended work on any fiberglass material, wallboard, spackling compound or plaster. During any use on these materials, it is extremely important that the tool is cleaned frequently by blowing with an air jet.

⚠ WARNING: Always wear safety goggles or safety glasses with side shields during power tool operations, or when blowing dust. If operation is dusty, also wear a dust mask.

ROUTINE MAINTENANCE

⚠ WARNING: **DO NOT** at any time let brake fluids, gasoline, petroleum-based products, penetrating oils, etc. come in contact with plastic parts. Chemicals can damage, weaken or destroy plastic, which may result in serious personal injury.

Periodic maintenance allows for long life and trouble-free operation. A cleaning, lubrication and maintenance schedule should be maintained. As a common preventive maintenance practice, follow these recommended steps:

1. When work has been completed, clean the tool to allow smooth functioning of the tool over time.
2. Use clean damp cloths to wipe the tool.
3. Check the state of all electrical cables.
4. Keep the motor air openings free from oil, grease and sawdust or woodchips, and store tool in a dry place.
5. Be certain that all moving parts that are exposed are well lubricated, particularly after lengthy exposure to damp and/or dirty conditions.

LUBRICATION

All of the bearings in this tool are lubricated with a sufficient amount of high-grade lubricant for the life of the tool under normal operating conditions. Therefore, no further lubrication is required.

TROUBLESHOOTING

If the blade does not follow a straight line:

- Teeth are dull. This is caused by hitting a hard object such as a nail, dulling teeth on one side. The blade tends to cut to the side with the sharpest teeth.
- Base is out of line or bent.
- Blade is bent.
- Edge guide or straight edge is not being used.

If the blade binds or smokes from friction:

- Blade is dull.
- Blade is on backwards.
- Blade is bent.
- Workpiece is not properly supported.
- Incorrect blade is being used.

ACCESSORIES

⚠ WARNING: The use of attachments or accessories that are not recommended for this tool might be dangerous and could result in serious injury.

Sears and other Craftsman outlets have a large selection of 7 1/4-inch Craftsman steel carbide-tipped blades designed for specific cutting applications. Contractor bulk packs are also available.

Sears and other Craftsman outlets also offer sawhorses, combination and framing squares, straight edges, edge guides, and a large assortment of clamps to help you with all your sawing needs.

Visit your local Sears store or other Craftsman outlets or shop sears.com/craftsman.

NOTES

Get it fixed, at your home or ours!

Your Home

For expert troubleshooting and home solutions advice:

manage my home

www.managemyhome.com

For repair – **in your home** – of **all** major brand appliances, lawn and garden equipment, or heating and cooling systems, **no matter who made it, no matter who sold it!**

For the replacement parts, accessories and owner's manuals that you need to do-it-yourself.

For Sears professional installation of home appliances and items like garage door openers and water heaters.

1-800-4-MY-HOME® (1-800-469-4663)

Call anytime, day or night (U.S.A. and Canada)

www.sears.com www.sears.ca

Our Home

For repair of carry-in items like vacuums, lawn equipment, and electronics, call anytime for the location of your nearest

Sears Parts & Repair Service Center

1-800-488-1222 (U.S.A.) **1-800-469-4663** (Canada)

www.sears.com www.sears.ca

To purchase a protection agreement on a product serviced by Sears:

1-800-827-6655 (U.S.A.) **1-800-361-6665** (Canada)

Para pedir servicio de reparación a domicilio, y para ordenar piezas:

1-888-SU-HOGAR®
(1-888-784-6427)

Au Canada pour service en français:

1-800-LE-FOYER^{MC}
(1-800-533-6937)
www.sears.ca

Sears

© Registered Trademark / TM Trademark / SM Service Mark of Sears Brands, LLC
© Marca Registrada / TM Marca de Fábrica / SM Marca de Servicio de Sears Brands, LLC
^{MC} Marque de commerce / ^{MD} Marque déposée de Sears Brands, LLC

© Sears Brands, LLC